



TF-100



TF-110



DC JACK
(CHARGE)

RS-232C

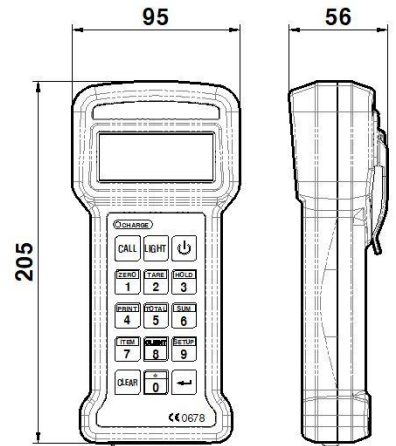

FEATURE

- ◆ Handy type (Weight:420g)
- ◆ Wireless Communication : ZigBee
- ◆ Possible to store weight value : 2,500pcs
- ◆ Item & Client Management : Each 70pcs
- ◆ External 1 Serial Port, RS-232 (For PC / Serial Printer)
- ◆ Interface with Crane Scale & Wheel Load Scale(TF-110) & Indicator

MODEL	TF-100	TF-110
Display	5digit LCD (Height : 15mm) , LED Back Light	2.4inch OLED [dots : 128(W) x 64(H) size : 55(W) x 27.5(H)mm]
Battery life	Approx. 90hr	Approx. 40hr
Internal battery	Lithium Polymer Battery	
Keypads	15 Key	
Display lamp	Zero, Tare, Hold, Stable, Low Battery, Charger	
Case material	Engineering Plastic	
Temperature range	-10℃ ~ 40℃	
Frequency	2.4 GHz	
RF Output Power	Max. 4dBm	
Effective distance	100m (Open Space)	
Parts	DC 5V, 1A Charge adaptor	

How to enjoy wireless communication with various products

ex-1

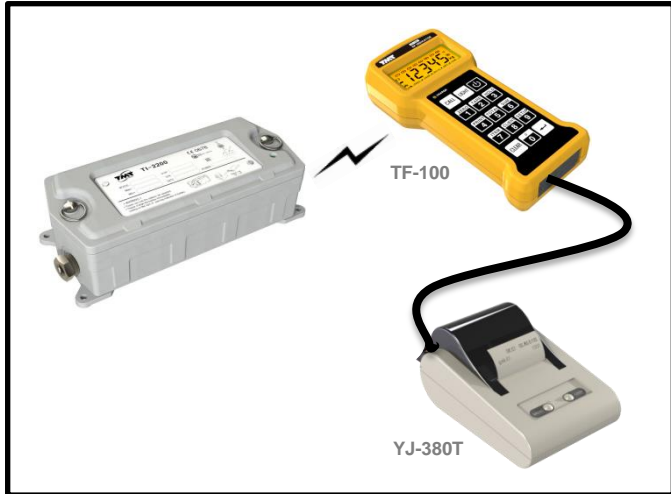

ex-2



ex-3



ex-4

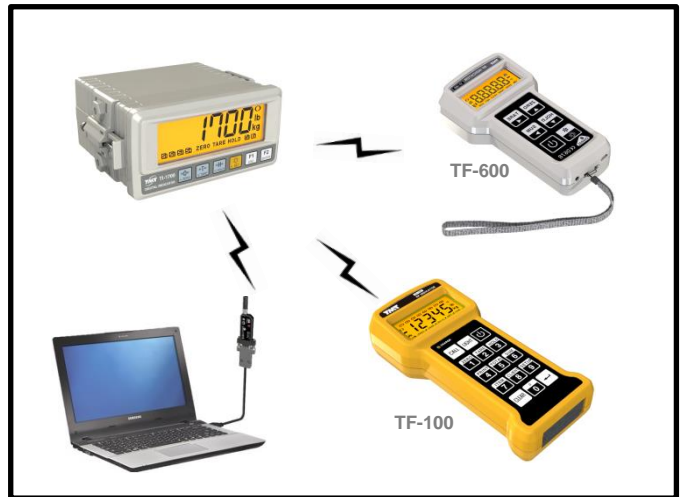

ex-5

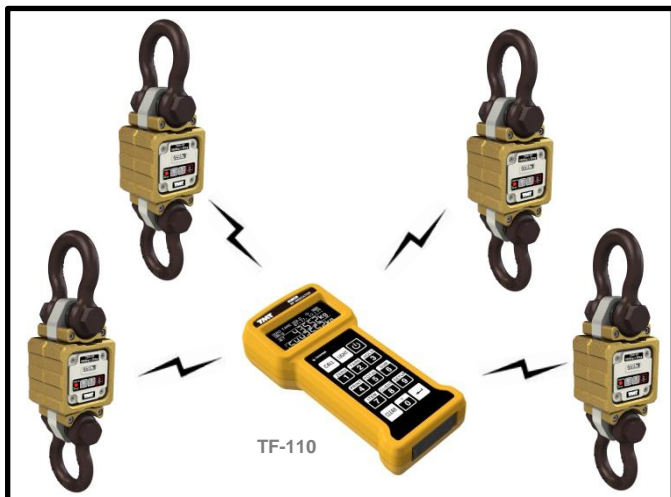

ex-6

